

YH冶金电动葫芦

YH Electric Hoist for Metallurgy

产品概述:

1. 冶金电动葫芦主要用于吊运熔融金属;
2. 起重量 $\leq 10t$, 起高度 $\leq 20m$, 工作环境温度 $-20\sim 60^{\circ}C$;
3. 具有双制动、双限位、隔热板等多种保护功能。

Product Introduction:

1. Metallurgical electric hoist mainly used for lifting molten metal.
2. Lifting capacity $\leq 10t$, Lifting height $\leq 20m$, Work environment temperature $-20\sim 60^{\circ}C$.
3. With double brakes, double limits, thermal baffle felt etc. many kinds of protection functions.

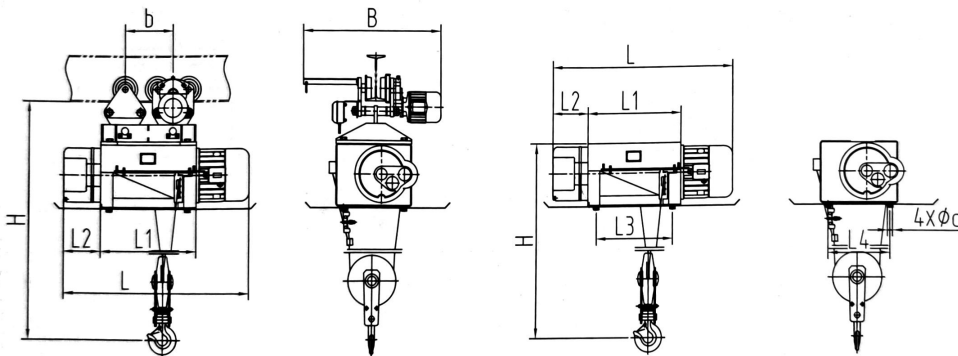

YH_{II} 2-5吨 (H=9-20米)

Model YH_{II} 2-5t (H=9-20m)

YH_{II} 固定式2-5吨 (H=9-20米)

Model YH_{II} Stationary 2-5t (H=9-20m)

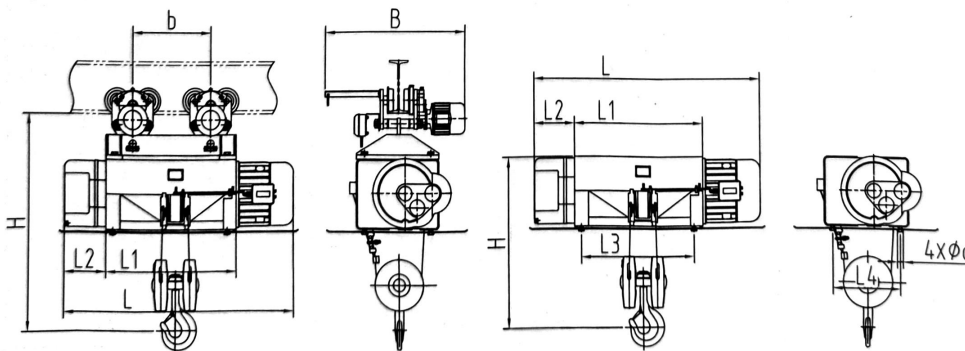

YH_{II} 10吨 (H=9-20米)

Model YH_{II} 10t (H=9-20m)

YH_{II} 固定式10吨 (H=9-20米)

Model YH_{II} Stationary 10t (H=9-20m)

YH Electric Hoist for Metallurgy

起重量	Capacity(t)	2					3					5					10									
型号	Type	YH _n																								
起升高度	Hoisting height (m)	9	12	15	18	20	9	12	15	18	20	9	12	15	18	20	9	12	15	18	20					
起升速度	Hoisting speed (m/min)	8 (8/2)															7(7/1.75)									
运行速度	Travel speed (m/min)	20																								
钢丝绳	绳径 Dia(mm)	11					13					15														
绳	结构 Specification	6x37+IWR																								
运行轨道	Track	20a-28b										25a-45a					32b-45a									
最小曲率半径	Min curvature radius (m)	2	3	4	5	6	2	3	4	5	6	2.5	3	4	5	6	3.5	4	6	7.5	9					
起升电机	型号 Type	ZD,31-4(ZDD32-4/16)					ZD,32-4(ZDD41-4/16)					ZD,41-4(ZDD51-4/16)					ZD,51-4(ZDD52-4/16)									
	功率 Power(kW)	3.0(3.0/0.75)					4.5(4.5/1.25)					7.5(7.5/2.0)					13(13/3.25)									
	转速 Rotation speed (r/min)	1380/345					1380/290					1400/345					1400/300									
	电流 Current(A)	7.6(6.5/7.1)					11(13.1/12.8)					18(18/17.5)					30(30/31)									
运行电机	型号 Type	ZDY,12-4										ZDY,21-4					ZDY,21-4									
	功率 Power(kW)	0.4										0.8					0.8x2									
	转速 Rotation speed (r/min)	1380																								
	电流 Current(A)	1.25										2.4														
结合次数	No.of connecting (次)	300																								
工作制度	Working system	FC=50%																								
电源	Power source	三相交流 Three phase AC 380V 50Hz																								
基本尺寸	L	1044	1147	1250	1353	1424	1110	1213	1316	1419	1490	1256	1356	1456	1556	1626	1647	1828	2009	2190	2310					
	L1	559	662	765	868	939	559	662	765	868	939	600	700	800	900	970	950	1131	1312	1493	1613					
	L2	192					234					272					278									
	L3	439	542	645	748	819	439	542	645	748	819	470	570	670	770	840	825	1006	1187	1368	1488					
	L4	362					362					448					486									
	b	205	332	435	538	609	205	332	435	539	609	228	352	452	552	622	574	755	936	1117	1237					
	B	950										1055														
	H	1300					1315					1400					1590					1600				
	d	25																								
自重 ±10%	运行 Operate	Crane Weight (kg)	439	457	479	494	505	475	493	515	530	541	679	752	776	794	809	1169	1221	1282	1326	1396				
	固定 Fix	Crane Weight (kg)	409	427	449	464	475	445	463	485	500	511	644	717	741	759	774	1129	1181	1242	1286	1356				