

QC型5~10t电磁桥式起重机

QC Overhead Crane with magnet Cap. 5-10t

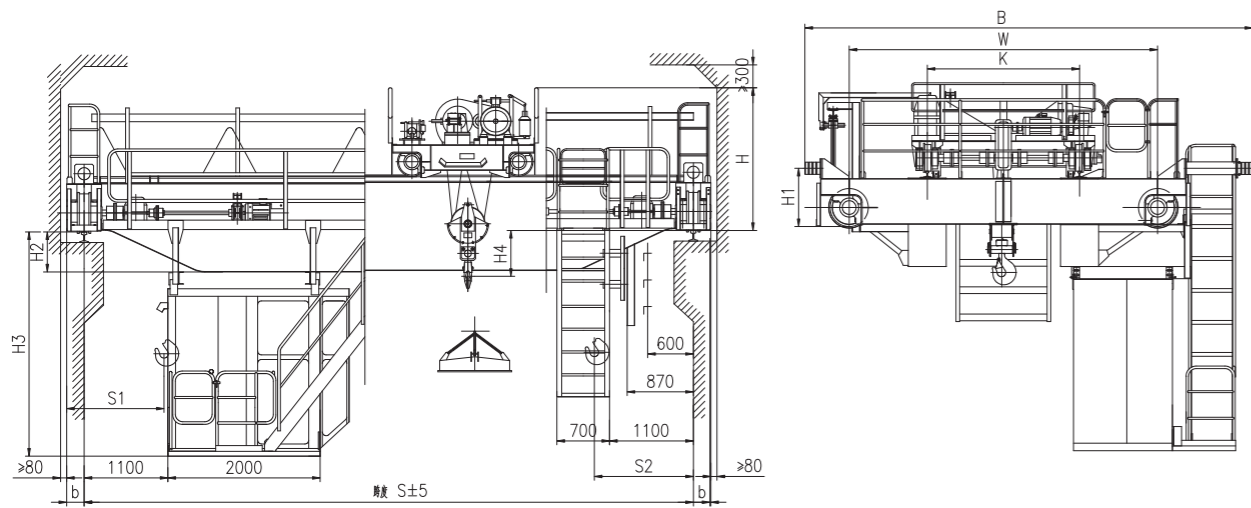

QC型16/3.2~20/5t电磁桥式起重机

QC Overhead Crane with magnet Cap. 16/3.2-20/5t

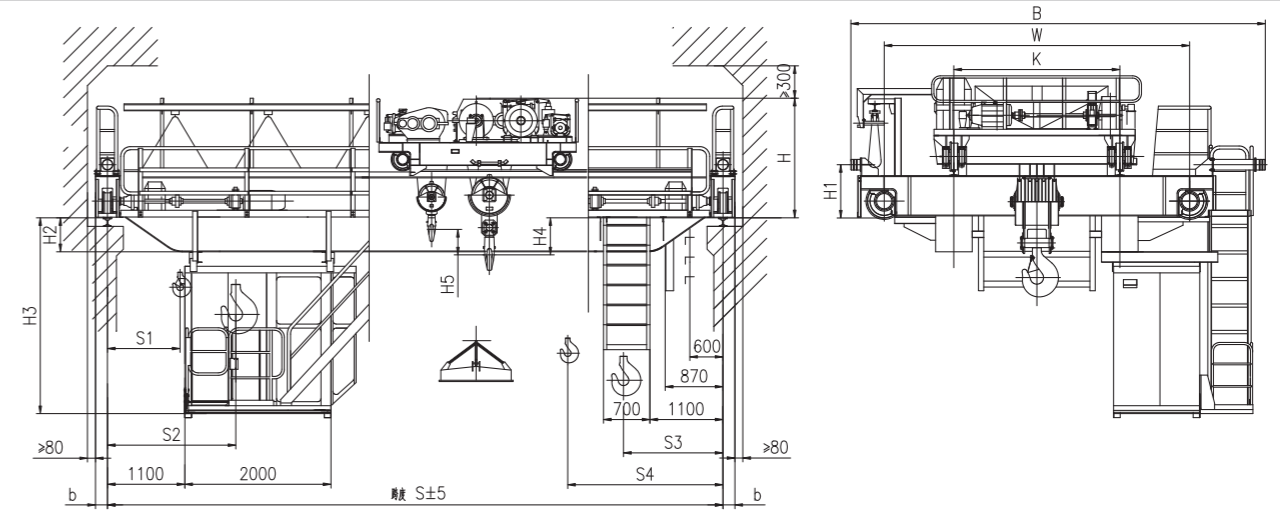

技术规格 Technical Specifications

起重量 Lifting capacity	t	5										10																		
跨度 Span	m	10.5	13.5	16.5	19.5	22.5	25.5	28.5	31.5	10.5	13.5	16.5	19.5	22.5	25.5	28.5	31.5													
起升高度 Lifting Height		16										16																		
工作制度 Duty		A6										A6																		
速度 Speed	起升 Hoisting	15.5										10.4																		
	小车运行 Crab travelling	37.2										39.5																		
	大车运行 Crane travelling	115.6					116.8					115.6					116.8					112.5								
极限尺寸 limit dimension	S1	1250										1500																		
	S2	1500										1500																		
主要尺寸 main dimension	H	1765										1878					1928													
	H1	765					800					765					850													
	H2	-22	128	228	378	528	678	828	978	-22	128	228	378	528	630	780	930													
	H3	2398	2548	2648	2798	2948	3098	3248	3398	2398	2548	2648	2798	2948	3050	3200	3350													
	H4	69										600					550													
	K	1400										2000																		
	W	3400					3550					5000					4050					5000								
	B	5058					5208					6028					5708					5848					6388			
b	230										230																			
最大轮压 Max.Wheel Loading	kN	74.5	80	86.5	94	101.5	113	121.5	128.5	104	112	121	126	134	146	155	165													
电机总功率 Total Power	kw	27.8					31.8					35.5					39.5													
荐用钢轨 Crane Rail Recommended		43kg/m										43kg/m																		
电源 Power Supply		三相交流 3-Phase A.C.50Hz 380V										三相交流 3-Phase A.C.50Hz 380V																		

技术规格 Technical Specifications

起重量 Lifting capacity	主钩 Main	t	16										20																			
	副钩 Aux.		3.2										5																			
跨度 Span			10.5	13.5	16.5	19.5	22.5	25.5	28.5	31.5	10.5	13.5	16.5	19.5	22.5	25.5	28.5	31.5														
起升高度 Lifting Height	主钩 Main	m	16										12																			
	副钩 Aux.		18										14																			
工作制度 Duty			A6										A6																			
速度 Speed	主起升 Main	m/min	13										9.7																			
	副起升 Aux		14.5										12.7																			
	小车运行 Crab travelling		44.6										44.6																			
	大车运行 Crane travelling		112.5					101.4					112.5					101.4														
极限尺寸 limit dimension	S1		1040										1070																			
	S2		2460										2650																			
	S3		1600										1700																			
	S4		3020										3280																			
主要尺寸 main dimension	H		2097	2099	2189	2187				2099	2101	2191																				
	H1		815					940					815					940														
	H2		82	182	242	392	542	692	842	82	86	186	246	394	544	694	844															
	H3		2502	2602	2662	2812	2962	3112	3262	2502	2506	2606	2666	2814	2964	3114	3264															
	H4		727	725	635	637				699	697	607																				
	H5		768										496																			
	K		2000										2000																			
	W		4400					5000					4400					5000														
	B		6278					6188					6798					6278					6188					6798				
	b		230					260					230					260														
最大轮压 Max.Wheel Loading	kN	146	153	161	174	182	193	204	214	170	177	187	201	210	223	234	245															
电机总功率 Total Power	kw	64.5					71.5					69					76															
荐用钢轨 Crane Rail Recommended		43kg/m或QU70										43kg/m或QU70																				
电源 Power Supply		三相交流 3-Phase A.C.50Hz 380V										三相交流 3-Phase A.C.50Hz 380V																				

QC型32/5~50/10t电磁桥式起重机

QC Overhead Crane with magnet Cap. 32/5-50/10t

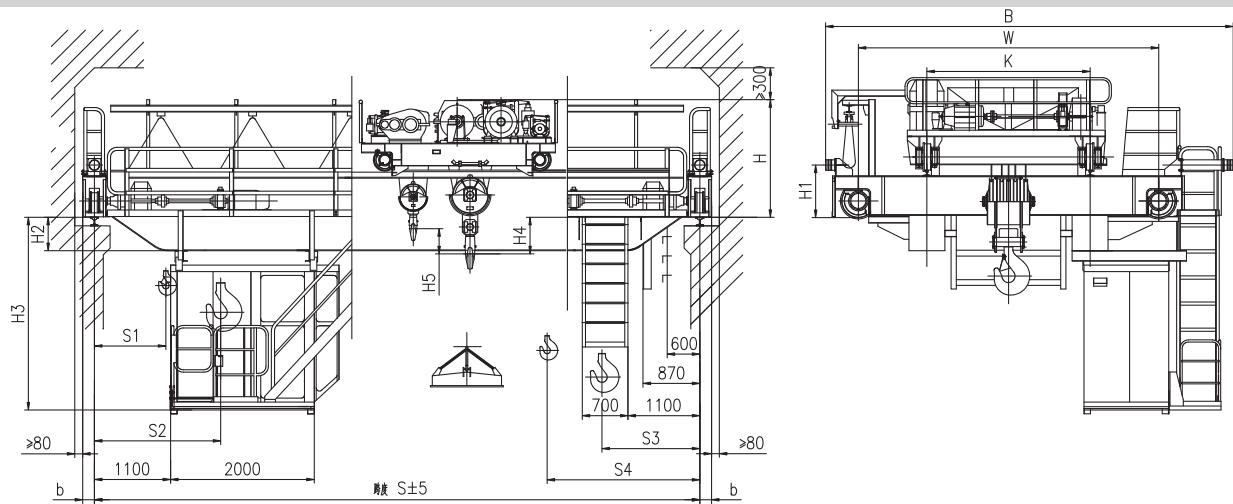

技术规格 Technical Specifications

起重量 Lifting capacity		主钩 Main 副钩 Aux.	t	32								50														
跨度 Span		m		10.5	13.5	16.5	19.5	22.5	25.5	28.5	31.5	10.5	13.5	16.5	19.5	22.5	25.5	28.5	31.5							
起升高度 Lifting Height	主钩 Main	m		16								12														
	副钩 Aux.	m		18								16														
工作制度 Duty				A6								A6														
速度 Speed	主起升 Main	m/min		9.5								7.8														
	副起升 Aux	m/min		12.7								13.2														
	小车运行 Crab travelling	m/min		42.4								38.5														
	大车运行 Crane travelling	m/min		101.4	101.8	86.8						86.8	87.3													
极限尺寸 limit dimension	S1	mm		1070								1005														
	S2	mm		2650								2785														
	S3	mm		1700								2000														
	S4	mm		3280								3780														
主要尺寸 main dimension	H	mm		2349	2353	2483					2746	2748	2754													
	H1	mm		905				1070				1055				1090										
	H2	mm		92	96	246	266	416	566	716	816	71	248	254	404	554	704	804	954							
	H3	mm		2512	2516	2666	2686	2836	2986	3136	3236	2491	2668	2674	2824	2974	3124	3224	3374							
	H4	mm		705	701	571					1020	1018	1012													
	H5	mm		790								948														
	K	mm		2500																						
	W	mm		4650				4700				5000				4800				5000						
	B	mm		6588				6608				6828				6828				6858				7058		
b	mm		260				300								300											
最大轮压 Max. Wheel Loading	kN		242	256	269	286	298	313	323	335	337	359	379	397	412	429	442	457								
电机总功率 Total Power	kw		96.3								96.3															
推荐钢轨 Crane Rail Recommended			QU70或方钢90								QU80或方钢100															
电源 Power Supply			三相交流 3-Phase A.C.50Hz 380V																							