

INTERNATIONAL  
STANDARD

**ISO**  
**10973**

First edition  
1995-07-15

---

---

**Cranes — Spare parts manual**

*Appareils de levage à charge suspendue — Manuel de pièces de rechange*



Reference number  
ISO 10973:1995(E)

## **Foreword**

ISO (the International Organization for Standardization) is a worldwide federation of national standards bodies (ISO member bodies). The work of preparing International Standards is normally carried out through ISO technical committees. Each member body interested in a subject for which a technical committee has been established has the right to be represented on that committee. International organizations, governmental and non-governmental, in liaison with ISO, also take part in the work. ISO collaborates closely with the International Electrotechnical Commission (IEC) on all matters of electrotechnical standardization.

Draft International Standards adopted by the technical committees are circulated to the member bodies for voting. Publication as an International Standard requires approval by at least 75 % of the member bodies casting a vote.

International Standard ISO 10973 was prepared by Technical Committee ISO/TC 96, *Cranes*, Subcommittee SC 5, *Use, operation and maintenance*.

Annexes A, B, C, D and E of this International Standard are for information only.

# Cranes — Spare parts manual

## 1 Scope

This International Standard establishes guidelines on the general requirements necessary for the preparation and presentation of spare parts manuals for cranes.

## 2 Presentation of the manual

### 2.1 General

A spare parts manual shall be provided by the crane manufacturer. This manual

- a) should be simple to understand and have adequate explanatory notes;
- b) shall incorporate the use of internationally recognized symbols, if established;
- c) should be easy to use, compact and made of durable hardwearing material;
- d) shall be compiled in the language normally used by the manufacturer, unless a specific language has been agreed on between the parties to the contract.

The manual is a working tool which should be both convenient and complete. The text should be simple and adapted to the individuals who will use it, with all information being explicit and comprehensive.

Illustrations, diagrams, graphs and tables should be used in preference to written text to avoid the risk of misunderstanding. They should be clear and simple, and be placed adjacent to any corresponding text.

The manual shall be presented in a manner that clearly and positively indicates that it is complete (for example each page shall be clearly numbered in sequence and the total number of pages in the manual

clearly shown, either on the first page only or on each individual page).

The terms (see ISO 4306), definitions, units (see ISO 31) and symbols shall comply with the relevant International Standards. When the units specified differ from those in common use, this should be noted in the manual in brackets or by means of a footnote.

Only those items relative to the particular crane model or series and its application shall be included.

### 2.2 Preliminary information

The following information shall be given on the front or back cover, or on the first pages of the manual:

- a) title of the manual;
- b) reference number of the manual (if any);
- c) identification (designation, type, series, model, etc.) of the crane with which the manual is intended to be used;
- d) serial number or numbers of crane or, where appropriate, range of serial numbers covered;
- e) name and full address of the crane manufacturer and/or his agent;
- f) table of contents and/or index.

### 2.3 Number of volumes

The spare parts manual, with the other manuals particular to the crane in question (for example driver's manual, user's manual, etc.), may be published in one or more volumes. The choice of the volume and grouping of the parts should be suitable for the type of product, its normal application and personnel requirements. Where appropriate, cross-reference to

other volumes should be made so that the same information is not repeated unnecessarily.

### 3 Content

The spare parts manual shall cover the complete crane. It is the common source of information for all maintenance and spare parts supply personnel.

The manual shall include identification and location for all items supplied as replacement parts or assemblies.

#### 3.1 General content

The following information should normally be included:

- a) index of major assemblies, showing page numbers and/or section;
- b) illustration of product, identifying major assemblies and applicable page number and/or section. Each major assembly should be identified so that it clearly defines the area of the crane covered (see annex A for a typical example);
- c) details of all constituent units of the crane, including identification of replacement parts assemblies and their part numbers;
- d) identification of all parts and part numbers on a diagram, photograph, etc. by a leader line or other suitable method (see annexes C and D);
- e) at the manufacturer's discretion, a numerical list or lists of all parts numbers, preferably grouped by major assemblies or pages. Where indexed separately, a reference to the page number on which the part is shown should be included (see annex B for a typical example);
- f) list of materials such as sealing compound, etc. for use in hydraulic and other fluid systems, stating the part number where appropriate;
- g) when parts which comply exactly with a national or International Standard are used, the appropriate standard reference, in addition to the manufacturer's identification, should be shown;
- h) identification on all pages, for example, publication date.

#### 3.2 Illustrations

Each illustration shall be identified by a suitable number and title. The presentation should preferably be a clear axonometric or other pictorial view, using exploded views to improve clarity and understanding (see annex D for a typical example).

Separate, enlarged views of intricate and complicated areas of the illustration should be provided as "detail views". Each part of an assembly shall be suitably designated with its part or index number to allow convenient reference to the parts list or index.

If a part (for example a hydraulic cylinder) is further illustrated in detail on another page, that page shall be referenced on the original page (see annex C for a typical example).

#### 3.3 Format of part list

A typical column heading layout is shown in table 1.

The quantity shown in column (3) should be the total number of component parts required for the assembly shown in the illustration.

The entry in column (4) should be brief and, where practicable, correspond to the recognized definition in an International Standard. Reference should be made to the master drawing, recorded in column (5), for full details of size, specification, etc.

If a component, such as a cylinder, contains parts that are included in a repair kit, such parts should be identified in the parts list by some means, for example an asterisk. Normally such repair kits contain oil seals, backup rings, etc. See annex D for a typical example.

**Table 1 — Column headings for parts list accompanying illustration**

Illustration reference number	Part number	Quantity	Description	Further details (e.g. references, remarks, etc.)
(1)	(2)	(3)	(4)	(5)

**Annex A**  
(informative)

**Examples of parts group and location**

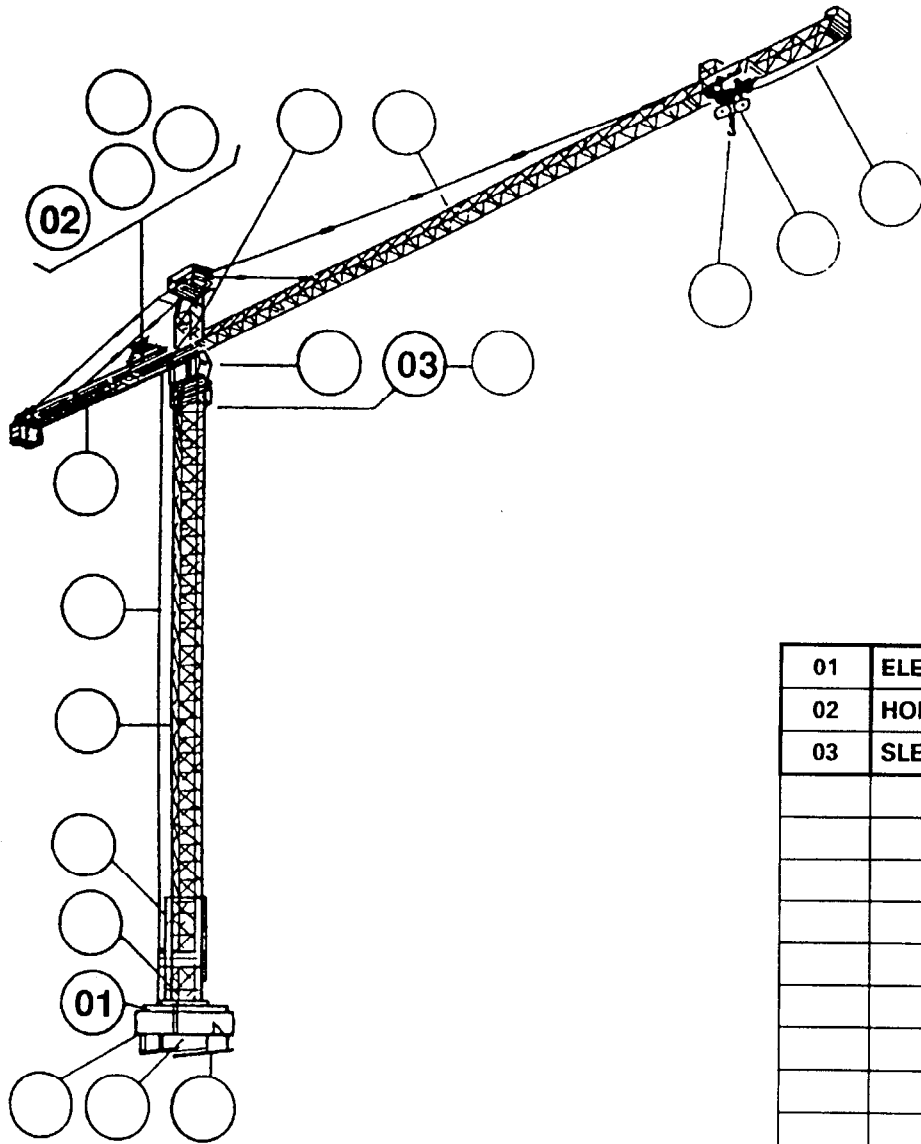

01	ELECTRICAL SUPPLY
02	HOIST MECHANISM
03	SLEWING MECHANISM

Publication date	Description	Page in group	Page in manual	Group number
93-12-17	Crane Type X 00 Identification of groups	01	0001	00

**Annex B**  
(informative)

**Example of numerical parts list**

Part number	Quantity	Description	Page reference
00315-23	1	Chain	02-0001 ----- 00
00319-01	1	Pipe	02-0001 ----- 00
00324-11	4	Screw F90 6PC M8×45 - 10.9	02-0100 ----- 02
00324-12	4	Screw (company standard)	03-0220 ----- 06
00324-15	4	Screw F90 6PC M10×35 - 10.9	05-0100 ----- 00
			05-0100 ----- 00
			05-0100 ----- 00
00324-27	4	Screw F90 M4×10 - 10.9	04-0230 ----- 01
			08-0400 ----- 02
			09-0430 ----- 01
			04-0230 ----- 00
			08-0400 ----- 01
			04-0230 ----- 03
			02-0700 ----- 02
00325-06	2	Screw C M3×12 - 3.6	03-0240 ----- 01
00329-10	2	Screw CHC M6×16 - 8.8	03-0240 ----- 02

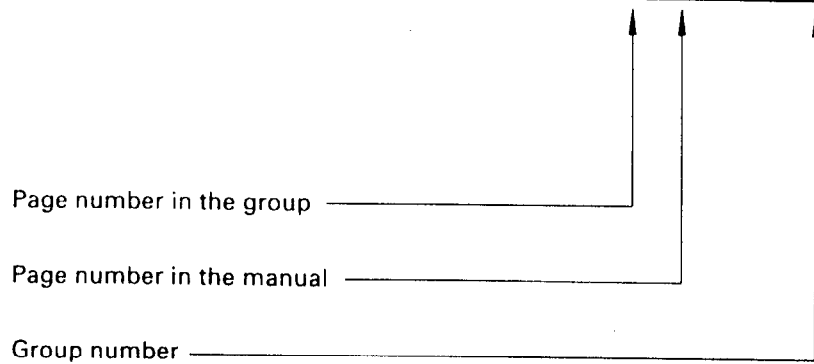

**Annex C**  
(informative)

**Example of assembly**



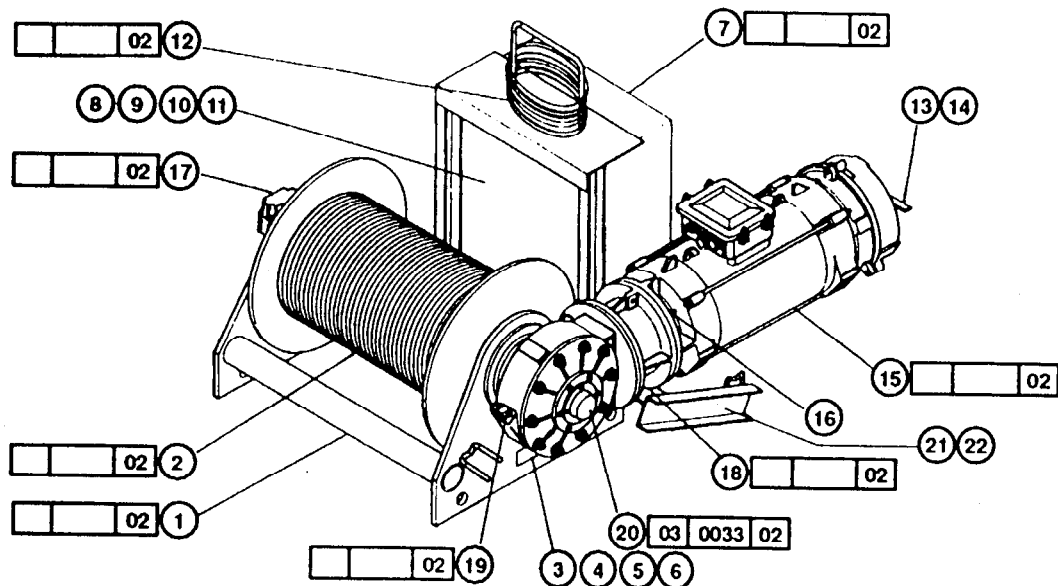

Illustration reference number	Part number	Quantity	Description	Further details <sup>1)</sup>
1	W-19481-43		Hoist mechanism	
2	K-33384-82	1	Chassis	R
3	002-0130-079-03	1	Drum	R
4	C-16228-13	2	Plate	
5	S-14410	1	Support	
6	W-00350-03	4	Washer	
7	C-00336-28	4	Bolt	
8	X-36994-79	1	Control panel	R
9	T-14410-13	1	Support	
10	D-00029-01	1	Chain	
11	E-09367-02	2	Link	
12	G-01018-27	1	Chute	
13	S-16261-16	1	Accessories	R
14	K-01340-99	2	Bolt	
15	G-01239-07	1	Brake release lever	
16	B-02439-16	1	Squirrel cage motor	R
17	S-00345-62	4	Safety nut	
18	B-02458-16	1	Limit switch	R
19	N-42389-35	1	Planetary gearbox	R
20	002-0180-017-00	1	Rubber stop	R
20A	K-42389-09	1	Bevel reduction gearbox	R
21	S-12032-15	1	Oil	
22	N-68475-72	1	Plate	
	P-18475-34	1	Adhesive	

<sup>1)</sup> R: Reference to another page for detail of components.

Publication date	Description	Page in group	Page in manual	Group number
93-12-17	Hoist mechanism	01	0030	02

**Annex D**  
(informative)

**Example of part with repair kit identification (exploded view)**

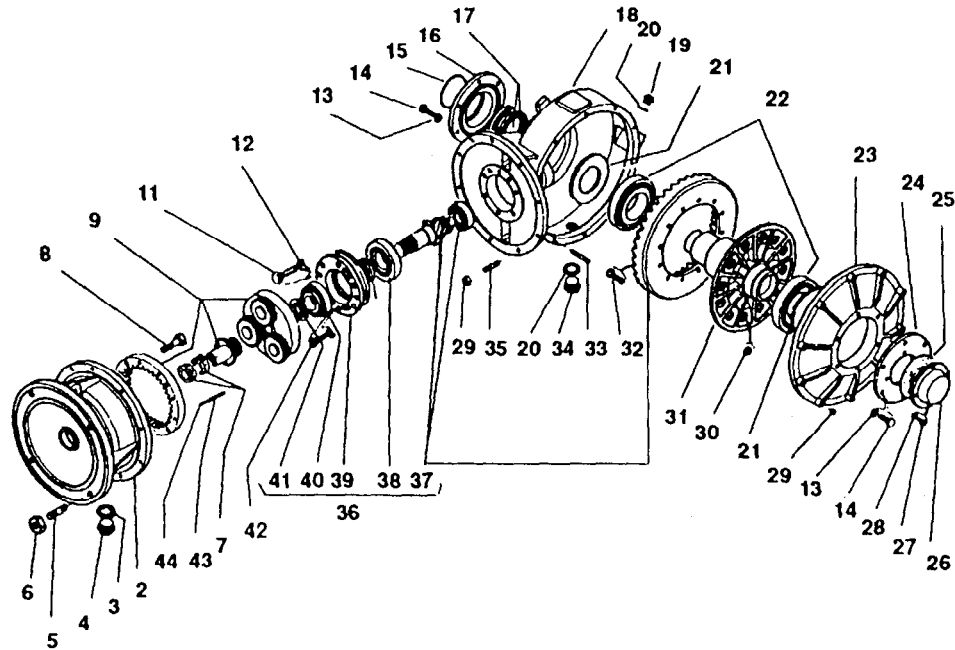

Illustration reference number	Part number	Quantity	Description	Further details <sup>1)</sup>
	K-42349-09		Bevel reduction gearbox	
29	D-01345-30	20	Nut	
30	Q-01345-41	12	Nut	
31	D-08389-05	1	Hub	
32	K-01330-64	12	Screw	
33	B-22277-81	10	Stud	
34	R-01374-63	2	Plug	
35	E-22277-84	10	Stud	
36	D-50384-52	1	Bevel gear unit	
37	T-40389-55	1	Bevel gear	
38	F-00398-87	1	Bearing	★
39	N-01289-27	1	Ball race	★
40	R-00398-74	1	Bearing	★
41	D-12389-67	1	Slotted nut	★
42	X-00330-49	5	Screw	★
43	K-00357-74	3	Expanded pin	
44	V-00236-86	3	Expanded pin	

<sup>1)</sup> ★: All these parts have to be changed at the same time.

Publication date	Description	Page in group	Page in manual	Group number
93-12-17	Bevel reduction gearbox	03	0033	02

## **Annex E**

(informative)

### **Bibliography**

- |  |  |
|--|--|
| [1] ISO 31-0:1992, <i>Quantities and units — Part 0: General principles.</i> | [3] ISO 4306-2:1994, <i>Cranes — Vocabulary — Part 2: Mobile cranes.</i> |
| [2] ISO 4306-1:1990, <i>Cranes — Vocabulary — Part 1: General.</i>           | [4] ISO 4306-3:1991, <i>Cranes — Vocabulary — Part 3: Tower cranes.</i>  |

---

---

**ICS 53.020.20**

**Descriptors:** handling equipment, lifting equipment, cranes (hoists), components, spare parts, handbooks.

Price based on 10 pages

---

---

