Cranes — Test code and procedures

Appareils de levage à charge suspendue — Code et méthodes d'essai



PDF disclaimer

This PDF file may contain embedded typefaces. In accordance with Adobe's licensing policy, this file may be printed or viewed but shall not be edited unless the typefaces which are embedded are licensed to and installed on the computer performing the editing. In downloading this file, parties accept therein the responsibility of not infringing Adobe's licensing policy. The ISO Central Secretariat accepts no liability in this area.

Adobe is a trademark of Adobe Systems Incorporated.

Details of the software products used to create this PDF file can be found in the General Info relative to the file; the PDF-creation parameters were optimized for printing. Every care has been taken to ensure that the file is suitable for use by ISO member bodies. In the unlikely event that a problem relating to it is found, please inform the Central Secretariat at the address given below.



COPYRIGHT PROTECTED DOCUMENT

© ISO 2009

All rights reserved. Unless otherwise specified, no part of this publication may be reproduced or utilized in any form or by any means, electronic or mechanical, including photocopying and microfilm, without permission in writing from either ISO at the address below or ISO's member body in the country of the requester.

ISO copyright office
Case postale 56 • CH-1211 Geneva 20
Tel. + 41 22 749 01 11
Fax + 41 22 749 09 47
E-mail copyright@iso.org
Web www.iso.org

Published in Switzerland

Contents

Page

Foreword.....	iv
1 Scope	1
2 Normative references	1
3 Types of testing and inspection procedures	1
4 Test and inspection procedures	2
4.1 Conformity tests and inspections	2
4.2 Visual inspections	3
4.3 Load lifting tests	3
4.3.1 General	3
4.3.2 Static tests	3
4.3.3 Dynamic tests	4
4.3.4 Stability tests	4
5 Test conditions	5
6 Test report	5
Annex A (normative) Stability test and test conditions for mobile cranes	6
Bibliography	10

Foreword

ISO (the International Organization for Standardization) is a worldwide federation of national standards bodies (ISO member bodies). The work of preparing International Standards is normally carried out through ISO technical committees. Each member body interested in a subject for which a technical committee has been established has the right to be represented on that committee. International organizations, governmental and non-governmental, in liaison with ISO, also take part in the work. ISO collaborates closely with the International Electrotechnical Commission (IEC) on all matters of electrotechnical standardization.

International Standards are drafted in accordance with the rules given in the ISO/IEC Directives, Part 2.

The main task of technical committees is to prepare International Standards. Draft International Standards adopted by the technical committees are circulated to the member bodies for voting. Publication as an International Standard requires approval by at least 75 % of the member bodies casting a vote.

Attention is drawn to the possibility that some of the elements of this document may be the subject of patent rights. ISO shall not be held responsible for identifying any or all such patent rights.

ISO 4310 was prepared by Technical Committee ISO/TC 96, *Cranes*, Subcommittee SC 4, *Test methods*.

This second edition cancels and replaces the first edition (ISO 4310:1981), which has been technically revised.

Cranes — Test code and procedures

1 Scope

This International Standard specifies tests, inspections and procedures for verifying the conformance of a crane with its operational specifications and its capability to lift rated loads (see ISO 7363).

This International Standard is applicable to the types of cranes designated in ISO 4306-1, prior to first use following manufacture or after modification or repair of the load-bearing structure or a component of an individual crane.

Where rated loads are governed by stability, a test procedure and test load are specified that permit stability margins to be easily verified.

2 Normative references

The following referenced documents are indispensable for the application of this document. For dated references, only the edition cited applies. For undated references, the latest edition of the referenced document (including any amendments) applies.

ISO 4306-1, *Cranes — Vocabulary — Part 1: General*

ISO 7363, *Cranes and lifting appliances — Technical characteristics and acceptance documents*

ISO 11629, *Cranes — Measurement of the mass of a crane and its components*

ISO 13202, *Cranes — Measurement of velocity and time parameters*

ISO 14518, *Cranes — Requirements for test loads*

3 Types of testing and inspection procedures

3.1 Three types of test and inspection procedures are to be used to accomplish the aims of this International Standard:

- a) testing and inspection of cranes for conformity to specifications, as required in 4.1;
- b) visual inspection, as required in 4.2;
- c) testing of cranes for lifting loads, as required in 4.3.

3.2 Manufactured cranes ready for service shall be tested and inspected by the manufacturer prior to delivery. Cranes mounted or finally assembled at their places of use shall be tested and inspected prior to being put into service. Any agreements between the manufacturer/vendor and the purchaser¹⁾ shall include test and inspection.

In the case of serially manufactured cranes, the sample number of cranes to be tested and inspected should be established by mutual agreement between the manufacturer/vendor and the purchaser.

4 Test and inspection procedures

4.1 Conformity tests and inspections

When cranes are tested and inspected for conformity to specifications, the tests and inspections shall be performed according to the crane load characteristics as defined in ISO 7363.

The following parameters shall be verified:

- mass of the crane;
- distance from axis of rotation to the tilt axis;
- load lifting height;
- hook approaches;
- load lifting/lowering speed;
- precision load lowering speed;
- crane travelling speed;
- crab traversing speed;
- slewing speed;
- derricking/luffing time;
- telescoping time;
- cycle time (where necessary);
- functioning of limiting, indicating and safety devices;
- performance of driving medium, for example, motor currents under test load conditions.

Verify the above parameters wherever practical.

Measure the mass of the crane and its components in accordance with ISO 11629.

Measure the velocities and time parameters in accordance with ISO 13202.

1) In legal terms, the manufacturer/vendor and the purchaser are understood to be the parties who signed the contract. The manufacturer/vendor is the party supplying the crane. The purchaser is the party who receives the crane according to the contract.

4.2 Visual inspections

A visual inspection shall be carried out, which should include checking for compliance with specifications and/or condition of all vital components, including the following:

- mechanisms, electrical and hydraulic equipment, safety devices, brakes, controls, lighting and signalling systems;
- crane steel structures and their connections, ladders, means of access, cabins, platforms;
- all guarding;
- hook or other load-handling attachments and their connections;
- ropes and their fastenings;
- sheave blocks, their pivots and fastening details, and jib linkage elements.

It shall not be inferred that the dismantling of any parts is necessary during this inspection. Nevertheless, the opening of covers (e.g. limit switch covers), as required for normal service and inspection purposes, shall be included.

This inspection procedure shall also include verification that acceptance documents have been submitted in compliance with ISO 7363, and that they have been checked.

4.3 Load lifting tests

4.3.1 General

Load lifting tests shall include the following:

- static tests;
- dynamic tests;
- stability tests (where applicable).

Test loads shall be composed, measured and applied during testing in accordance with ISO 14518.

4.3.2 Static tests

4.3.2.1 Static tests are conducted for demonstrating the ability of the crane to lift rated loads and the competence of some structural components. Such tests shall be considered to be successful if no crack, permanent deformation, paint flaking or damage that affects the function and safety of the crane is visible and no connection has been loosened or damaged.

4.3.2.2 Perform separate static tests for each hoisting mechanism and its concurrent operation, if permitted by the crane specifications, in such positions and configurations as will impose maximum rope loads, maximum bending moments and/or maximum axial forces, as applicable, on the major crane components. The test load, built up progressively, shall be lifted 100 mm to 200 mm from the ground and suspended for a period necessary for the test, but not less than 10 min, unless a higher value is required by national regulations or is specified in the purchase contract.

Where it is impossible to impose in one static test the maximum bending moments and/or axial forces in any major component of the crane, carry out an additional static test or tests that create the required forces in those components.

4.3.2.3 The test load shall be $1,25 P$ for all cranes, unless a higher value is required by national regulations or is specified in the purchase contract, where P is:

- a) for mobile cranes, the rated capacity (the mass of the load on the hoisting mechanism, including payload and the mass of the hook assembly and of the rigging attachments);
- b) for other crane types, the maximum capacity as specified by the manufacturer.

4.3.3 Dynamic tests

4.3.3.1 Dynamic tests are conducted primarily for the purpose of verifying the functioning of crane mechanisms and brakes.

4.3.3.2 Perform a loading test on all the motions of the crane, with the exception of the hoisting mechanism, using a load of $1,25 P$ at reduced speeds, as specified by the crane manufacturer.

Perform dynamic testing using a load of $1,1 P$ separately for each crane motion or, if stated in the crane specifications, for concurrent crane motions, in such positions and configurations as will impose maximum loading on the mechanism(s). Testing shall include repeated starting and stopping for each motion throughout the range of the motion, and shall also include a mid-air start with the test load suspended. No uncontrolled movement shall occur with the test load under these conditions.

4.3.3.3 The dynamic test shall be considered as being successful if the components concerned have been found to perform their functions, if visual inspection subsequent to the test reveals no damage to the mechanism or structural components, and if no connection has been loosened or damaged.

4.3.3.4 During performance of the dynamic test, the crane shall be controlled according to the instructions specified in the operator's manual, and care shall be taken to limit accelerations, decelerations and speeds to those appropriate to normal crane operation.

4.3.4 Stability tests

4.3.4.1 The purpose of the stability test is to check the crane's ability to withstand overturning moments. The test shall be considered successful if the crane remains stable when the crane's hook is statically loaded.

4.3.4.2 Carry out the tests in those positions or configurations within the specified working area for which stability is at a minimum. If different loads are specified for different positions or working areas, perform a test to check the stability for a selection of those conditions.

4.3.4.3 The test load, built up progressively, shall be lifted 100 mm to 200 mm from the ground and suspended for a period necessary for the test, but not less than 5 min, unless a higher value is required by national regulations or specified in the purchase contract.

4.3.4.4 The test load shall be $1,25 P$ for all cranes excepting mobile cranes, unless a higher value is required by national regulations or specified in the purchase contract, where P is as specified by the manufacturer.

4.3.4.5 For mobile cranes, perform stability tests in accordance with Annex A.

5 Test conditions

5.1 For testing purposes, the crane shall be fitted with working equipment suitable for operation in accordance with specifications.

5.2 Cranes travelling on rail tracks shall be tested on rails manufactured and laid in conformity with the crane specifications.

5.3 Cranes other than those travelling on rail tracks shall be set up as specified by national regulations or in the purchase contract.

5.4 At the time of testing, wind speed shall not exceed 8,3 m/s (30 km/h). However, this should not be construed as requiring that the crane be orientated so as to receive the most unfavourable effects of wind, unless otherwise specified in the purchase contract.

6 Test report

On completion of the tests specified in 3.1, a report shall be prepared listing the conclusions and results.

The test report shall identify the crane tested, and give the date and location of the tests and the name of the test supervisor. It shall give specific information as to the loads, positions, configurations, procedures and findings in each case.

For cranes that are subject to visual inspection only, an abbreviated form of report may be used. The identity of the crane, date and location of inspection, name of inspector and the findings for each item inspected shall be included.

Annex A (normative)

Stability test and test conditions for mobile cranes

A.1 Stability test

A.1.1 Test load

Stability test loads shall be determined according to the following:

- a) on outriggers/crawlers:

$$1,25 P + 0,1 F_i$$

- b) on wheels (tyres), stationary:

$$1,33 P + 0,1 F_i$$

- c) on crawlers/wheels (tyres) with permissible travel speed up to 0,4 m/s:

$$1,33 P + 0,1 F_i$$

- d) on crawlers/wheels (tyres) with permissible travel speed over 0,4 m/s:

$$1,5 P + 0,1 F_i$$

where

P is the rated capacity — the mass of the load on the hoisting mechanism, including the payload and mass of the hook assembly and rigging attachments;

F_i is F_1 or F_2 — either the mass of the jib, m_J , or the mass of the fly jib, m_j , reduced to the head of the jib or fly jib.

If m_J is very high, or if the fly jib is designed for relatively light loads (i.e. the stability test loads exceed the strength of the fly jib), the stability test shall not be performed with the test load. The stability of the mobile crane shall instead be verified by calculation, as follows:

$$F_i = \frac{R_c \cdot m_J + m_j(R + r_c)}{R + r}$$

where

m_J is the mass of the jib;

m_j is the mass of the fly jib;

R is the radius of the jib;

r is the radius of the fly jib;

R_C is the radius of the centre of gravity of the jib;

r_C is the radius of the centre of gravity of the fly jib.

For cranes equipped with jib only:

$$r = r_C = m_j = 0$$

and

$$F_i = \frac{R_C}{R} \cdot m_J$$

For cranes equipped with both jib and fly jib:

— if the load is lifted on the jib head:

$$r = 0$$

and

$$F_1 = \frac{R_C \cdot m_J + m_j(R + r_C)}{R}$$

— if the load is lifted on the fly-jib head:

$$F_2 = \frac{R_C \cdot m_J + m_j(R + r_C)}{R + r}$$

The manufacturer shall provide the values of F_1 and F_2 in the crane documentation for minimum, intermediate and maximum lengths. If cranes are to operate in different positions or work areas, tests shall be carried out to check the stability for a selection of those conditions.

Figure A.1 shows the side elevation of a typical crane and the parameters for calculating stability.

A.1.2 Stability test criteria

The crane shall be considered to be stable if the test load specified in A.1.1 can be held by the crane at 100 mm to 200 mm above the ground for at least 5 min. The lifting of outriggers or their other movements is not an indication of lack of stability. Lifting of the supporting mass of the outrigger beams, on the unloaded side of the crane, is usually necessary to obtain a balance point.

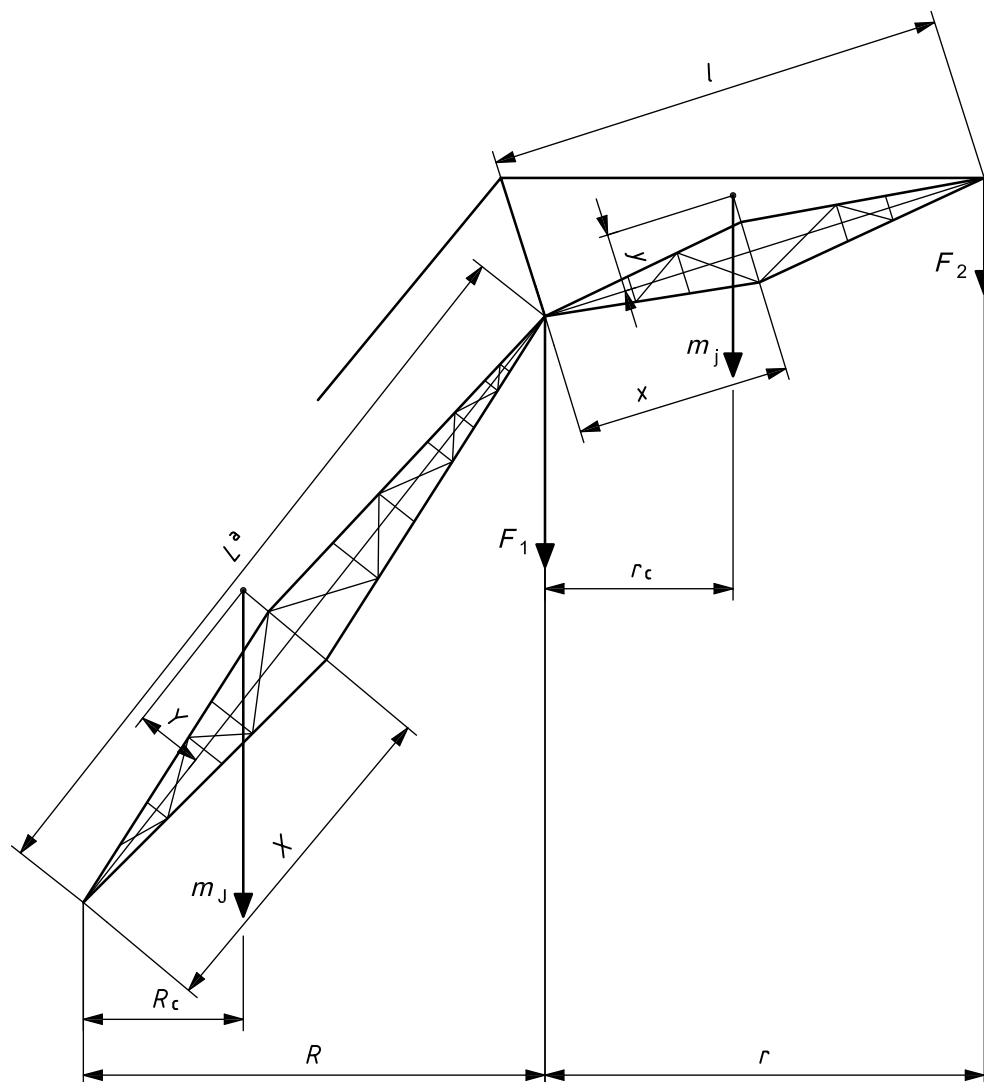

Key

- R jib radius
 - r fly-jib radius
 - L jib length ^a
 - l fly-jib length
 - R_c jib centre-of-gravity radius
 - r_c fly-jib centre-of-gravity radius
 - X, Y jib centre-of-gravity coordinates
 - x, y fly-jib centre-of-gravity coordinates
- See definitions given in A.1.1.

^a For telescopic jibs, L will correspond to the jib length under consideration.

Figure A.1 — Parameters for calculating mobile crane stability

A.2 Test conditions

A.2.1 When testing cranes on pneumatic tyres or crawler equipment, the appliance shall be placed on a firm level surface within $\pm 0,5$ % gradient.

Supporting conditions for tyres or crawler tracks shall conform with manufacturer's requirements.

When testing pneumatic tyred equipment while operating on tyres, the tyres shall be inflated to within ± 3 % of the pressure stipulated by the manufacturer, and all wheels shall be in the ahead position.

A.2.2 For testing cranes with outriggers in the *on outriggers* condition, the crane shall be level within $\pm 0,5$ % gradient.

A.2.3 When outriggers are used in the course of testing pneumatic tyred cranes, the crane shall be raised by the outriggers so as to provide clearance between the ground and all the wheels, or to relieve all wheels of the weight of the crane, unless the manufacturer specifies otherwise. Supporting conditions and the position of outriggers shall conform with the manufacturer's requirements.

A.2.4 When outriggers are used in the course of testing crawler cranes, the crane shall be installed so as to provide for firm bearing of the outriggers on the supporting surface.

A.2.5 The fuel tank shall be between one third and two thirds full. Coolant, lubricating oil and hydraulic fluids shall be at operating levels as specified by the manufacturer/vendor.

Bibliography

- [1] ISO 4305, *Mobile cranes — Determination of stability*
- [2] ISO 9373, *Cranes and related equipment — Accuracy requirements for measuring parameters during testing*
- [3] ISO 10245-1, *Cranes — Limiting and indicating devices — Part 1: General*

